

An Overview of DC to DC Converters in PV Applications

S Krishnapriya, Unnikrishnan L, Tijina Treasa Ignatius,

Abstract—Photovoltaic energy conversion system is gaining importance day by day as it is clean, quiet and cheap. One of the main challenges is its low value of voltage produced. So, we go for dc to dc conversion where we can step up or step down the dc voltage produced.

In this paper, buck-boost converter and partial power converters are discussed. Buck-boost converters can be used to step up and step down the output voltage in order to obtain a regulated output. Partial power converters are becoming popular these days due to its higher conversion efficiency.

Index Terms— Buck-boost converters, Partial Power converters, Photovoltaic,

1. INTRODUCTION

As we know, in the present scenario, green electricity is gaining importance and solar energy is becoming a popular substitute. Thus we go for Photovoltaic (PV) technology. It is a clean, quiet and a renewable way. Moreover it also has the advantages of low cost, minimal maintenance requirements with the absence of moving parts, no CO₂ emission and thus pollution free. A basic block diagram for the production of electricity can be shown as in figure 1.

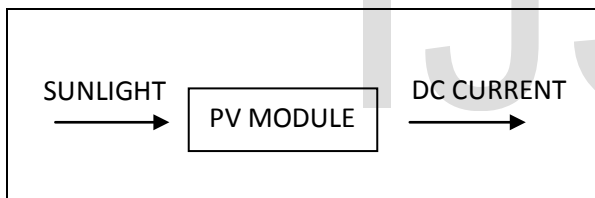

Fig 1: Generation of electricity

- S Krishnapriya is currently pursuing masters degree program in Industrial Drives and Control in Rajagiri School of Engineering and Technology, Kerala, India. E-mail: krishnapriyas22@ymail.com
- Unnikrishnan L is currently the assistant Professor in Department of Electrical and Electronics Engineering in Rajagiri School of Engineering and Technology, Kerala, India
- Tijina Treasa Ignatius is currently pursuing masters degree program in Industrial Drives and Control in Rajagiri School of Engineering and Technology, Kerala, India.

Some of the challenges in generating electricity by this technology is that : lower conversion efficiency, generation is climatic i.e., electricity produced depends on the light which in turn depends on the availability of sunlight which is present only during daytime, storage is difficult, produced electricity is low (usually 12

V) and is dc. Complete block diagram for a PV system is shown in figure 2.

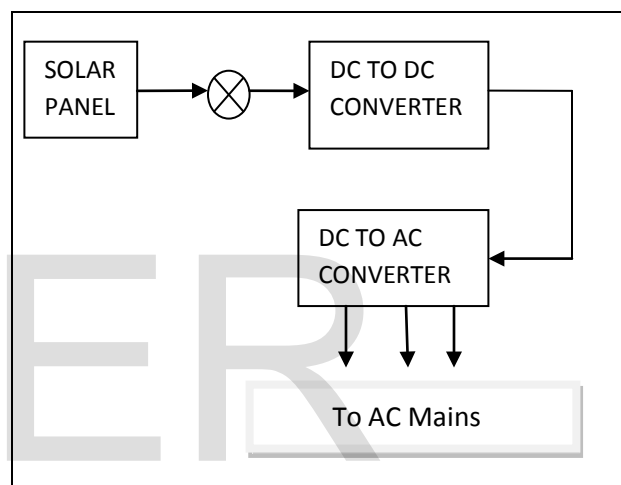

Fig 2: Block diagram for a PV system

In this paper, a comparative study of some of the available topologies in dc to dc converters is discussed. A buck-boost converter could be a solution for step up of dc current produced. Partial power converters are also gaining importance these days with their increased conversion efficiency.

2. BUCK-BOOST CONVERTERS

In order to obtain a regulated output from a solar panel, it is needed to step up and step down the input voltage. A buck-boost inverter can be used for this. It is possible to store the input voltage temporarily and produce the output when needed. Its operation can be assumed to have two modes: (a) when switch S is ON, and (b) when switch is OFF.

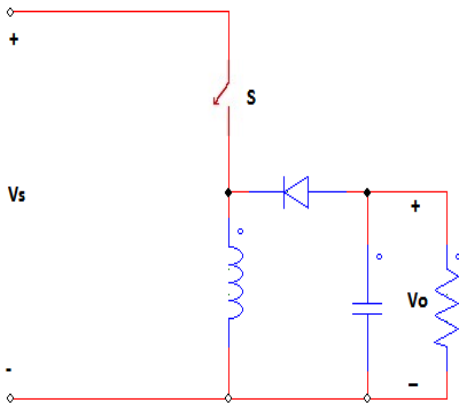

Fig 3: Buck Boost Converter

1.1. Mode 1 operation (when switch is ON):

When switch S is ON, input voltage is supplied to load as in figure 4(a) through inductor. Diode D is reverse biased.

1.2. Mode 2 operation (when switch is OFF):

When switch S is OFF, the energy stored in the inductor is supplied to load through diode as in figure 4(b).

This can operate in both continuous conduction mode (CCM) and discontinuous conduction mode (DCM). Depending on duty ratio ($D = t_{on}/T$), this topology can be used to step up or step down the duty ratio. Where t_{on} is the turn on time of the switch and T is time period which is the sum of turn on and turn off time. When $D=0.5$, output voltage is equal to input voltage. When $D<0.5$, output voltage is less than input and behaves as a step down converter. And when $D>0.5$, output voltage is greater than input voltage and behaves as a step up converter.

Thus a buck-boost converter has a simple design, can be used for step up or step down purposes, high efficiency, lower ripple voltages.

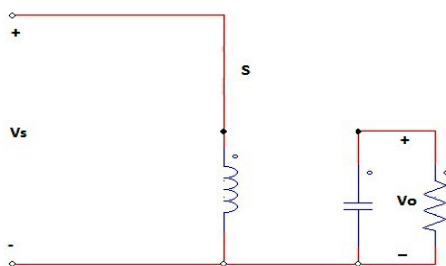

(a)Mode 1: when switch is ON

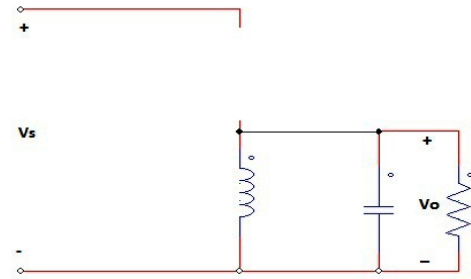

(b)Mode 2: when switch is OFF

Fig 4: Modes of operation of a Buck-Boost Converter

2. PARTIAL POWER CONVERTERS

Higher converter efficiencies of the order of 98% or above are needed for obtaining high energy yields. If the conversion efficiency is low, required energy yield is not obtained. Thus in order to improve the efficiency of the converter, a new topology is used: partial power converters. In this topology, only a fraction of input power is processed by the converter, remaining is directly fed forward to the output. Thus total output power is the sum of input

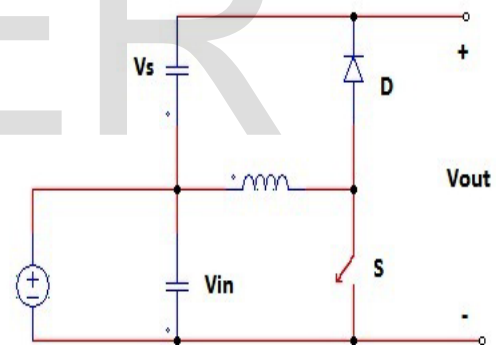

Fig 5: Partial power converter

power and dc-link output voltage. This topology helps to achieve efficiency close to 100% efficiency. Figure 5 shows the schematic of a partial boost power converter. And the output voltage is given by

$$V_{out} = V_s + V_{in} \quad (1)$$

$$\text{fraction of power processed} = \frac{V_s}{V_s + V_{in}} \quad (2)$$

Where V_s is the source capacitor voltage and V_{in} is the input voltage.

2.1. Mode 1 operation (when switch is ON):

When switch is ON, inductor current builds up (fig. 6(a)).

2.2. Mode 2 operation (when switch is OFF):

When switch is OFF, stored energy in the inductor starts flowing through the diode D and is discharged through the capacitor (fig. 6(b)).

4. CONCLUSION

As green electricity is becoming popular photovoltaic energy conversion systems are also becoming popular. Thus it is essential to design dc to dc converters with high efficiencies, simple and cheap. In this paper, buck-boost converter and partial power converters were discussed.

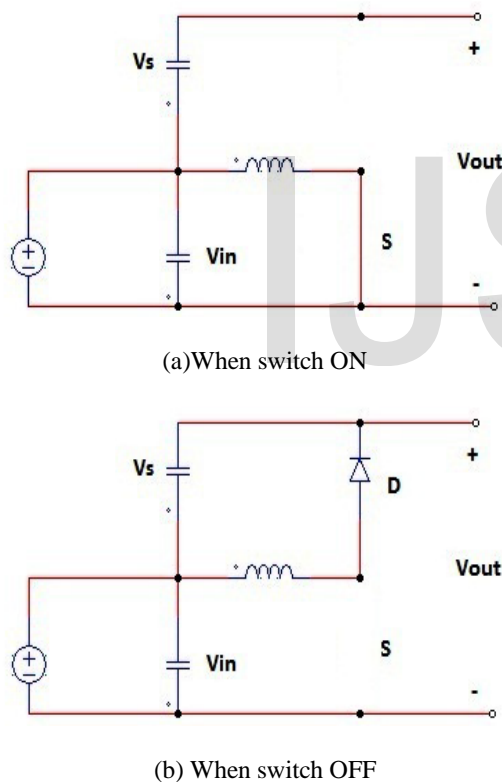

Fig 6: Modes of Operation of a Partial Power Converter

Buck-boost converters are simple and easy to design. They can be used to step up or step down the input voltage hence can obtain a regulated output. But it requires large switching frequencies under normal operating conditions and relatively large switching losses. They also require additional circuits for obtaining soft switching.

Partial power converters provide an alternative for dc to dc conversion. It gives high conversion efficiency and is cheap. Three level switching can be used for smooth operation. Its isolated and non-isolated topologies can be developed.

REFERENCES

- [1] Mohammed S. Agamy, Ahmed Elasser, Robert L. Steigerwald, Juan A. Sabate, Adam J. McCann, Li Zhang, and Frank J. Mueller "An Efficient Partial Power Processing DC/DC Converter for Distributed PV Architectures" IEEE transactions on power electronics, Vol.29,No.2, February 2014
- [2] Mohammed Agamy, Maja Harfman-Todorovic, Ahmed Elasser and Somasundaram Essakiappan " A Transformer-less partial power boost converter for PV applications using a three-level switching cell" 978-1-4673-4355-8/13/2013 IEEE
- [3] Ned Mohan, Tore M. Undeland, William P. Robbins, *Power Electronics: Converters, Applications and Design*, Third Edition, John Wiley & Sons, Inc.
- [4] Adam Tomaszuk, Adam Krupa, "Step-up DC/DC converters for photovoltaic applications – theory and performance" Przegląd Elektrotechniczny, ISSN 0033-2097, R. 89 Nr 9/2013
- [5] Peter Kosmatin, Marko Petkovšek, Danijel Vončina, "High-efficiency DC/DC converter for low-voltage applications" Electrotechnical Review: Ljubljana, Slovenija, 77(2-3): 109-113, 2010
- [6] B. Min, J. Lee, J. Kim, T. Kim, D. Yoo & E. Song, "A New Topology With High Efficiency Throughout All Load Range for Photovoltaic PCS," IEEE Transactions on Industrial electronics, Vol. 56, No. 11, Nov. 2009, pp. 4427-4435
- [7] N. Femia, G. Lisi, G. Petrone, G. Spagnuolo, and M. Vitelli, "Distributed maximum power point tracking of photovoltaic arrays: Novel approach and system analysis," IEEE Trans. Ind. Electron., vol. 55, no. 7, pp. 2610–2621, Jul. 2008.
- [8] N. Kaushika and N. Gautam, "Energy yield simulations of interconnected PV arrays," IEEE Trans. Energy Converse., vol. 18, no. 1, pp. 127–134, May 2003.
- [9] Byung-Duk Min, Jong-Pil Lee, Jong-Hyun Kim, Tae-Jin Kim, Dong-Wook Yoo, and Eui-Ho Song, "A New Topology With High Efficiency Throughout All Load Range for Photovoltaic PCS", IEEE Transactions On Industrial Electronics, Vol. 56, No. 11, November 2009